

# TYPICAL FLASH FILTERVENT™ INSTALLATIONS

On roof pitches of 3/12, 2" minimum space should be maintained.

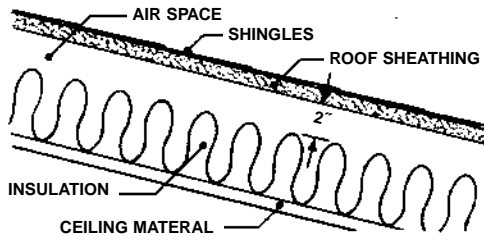

On roof pitches over 3/12, 1 1/2" minimum space should be maintained.

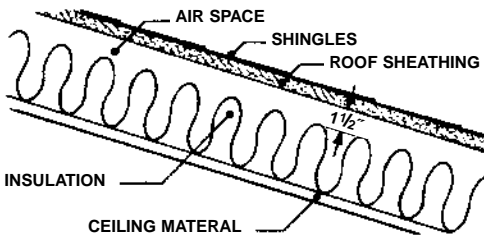

Soffit or eave vents supplying intake air for the Flash FilterVent should be continuous the full length of the roof. Flash FilterVent should run the full length of the roof.

**WARNING:**

If there is a roof above the vent, make sure that any water run off is diverted away from the area where Flash FilterVent is installed. Gutters are recommended.

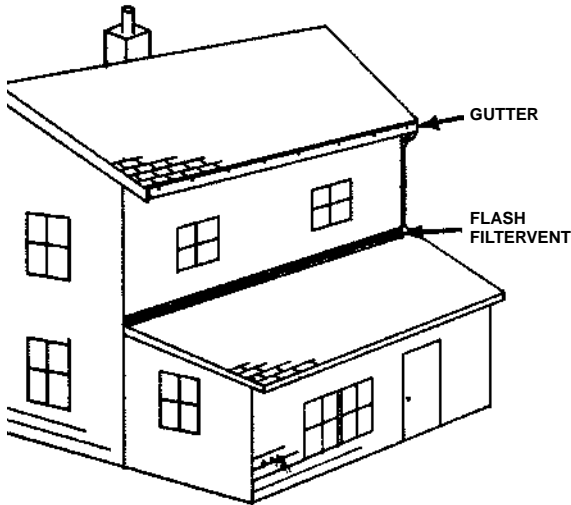

3000 West Commerce, Dallas, TX 75212  
 309-692-6969 FAX: 1-800-635-7006  
 www.airvent.com

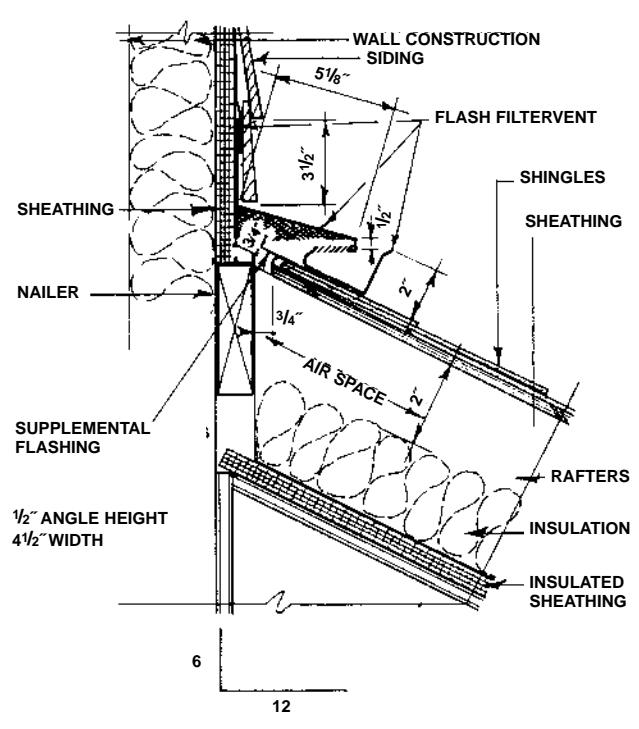

## Continuous Soffit Vent

The other half of a Flash FilterVent ventilation system is adding an area of at least equal net free area of soffit venting. Air Vent's Continuous Soffit Vent is designed for this purpose and will provide 9 sq. inches of net free area per linear foot. There are models for new construction, installed next to the fascia; and for existing or new soffits installed as close to the fascia as practicable.

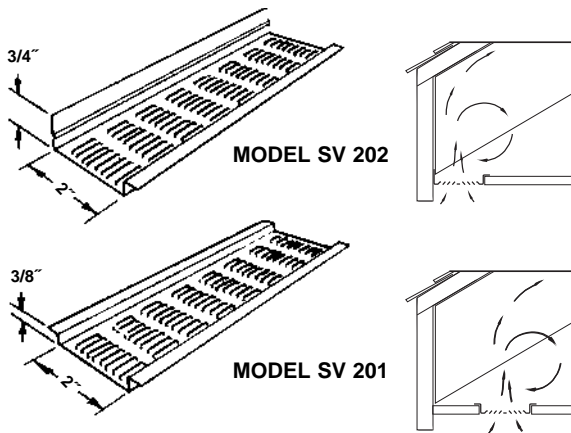

Application procedures and conditions are beyond the control of the manufacturer and/or seller of Flash FilterVent and for this reason neither manufacturer nor seller can be responsible for the failure of the product when not used according to instructions and specifications.

# FLASH FILTERVENT™ AND SUPPLEMENTAL FLASHING INSTALLATION INSTRUCTIONS

NOTE: Intended for roofs 3/12 to 12/12

## INSTALLATION – NEW CONSTRUCTION

- 1** Provide slot in sheathing where roof joins vertical wall as shown below, before roofing or siding is applied. Slot should be cut within 6" of inside of end wall of house. Do not extend slot over overhang of roof.

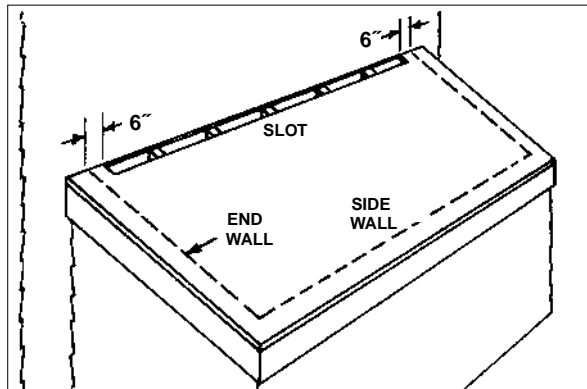
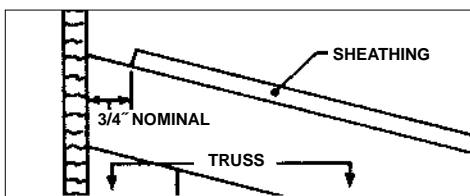

- 2** Shingle roof up to slot. Do not flash unslotted portion of roof at ends of slot, but let top course of shingles lay over it to form one thickness.



- 3** Place one section of Flash FilterVent over the open slot making sure the rear flange fits snugly against the sidewall sheathing and sufficient clearance is maintained over louvers to allow airflow. Do not crush Flash FilterVent.

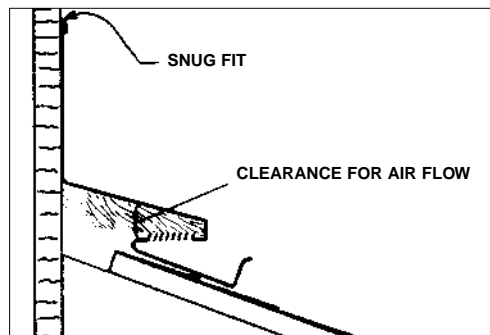

- 4** Mark on shingles the point where the Flash FilterVent apron turns up to form the baffle.

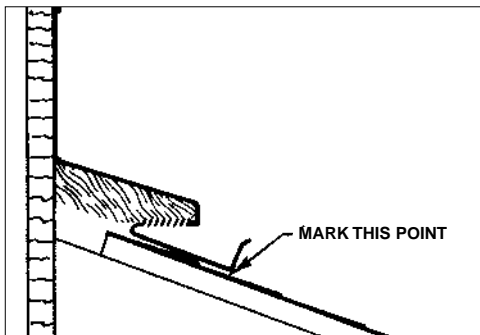

- 5** Measure distance from sidewall sheathing to point marked above and transfer measurement to opposite end of roof. Snap a chalk line between the two points. Use line as reference to install Flash FilterVent in proper alignment.

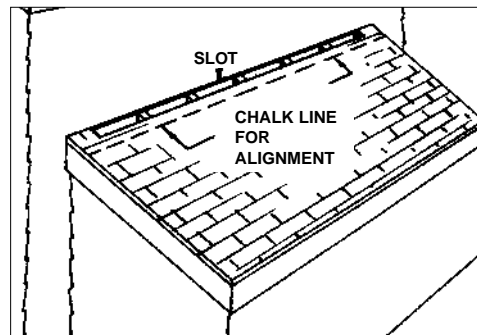

## INSTALLATION – NEW CONSTRUCTION

- 6** Place supplemental flashing over slot as shown in diagram without fastener. Caulk any low areas or gaps between the flashing and the shingles.

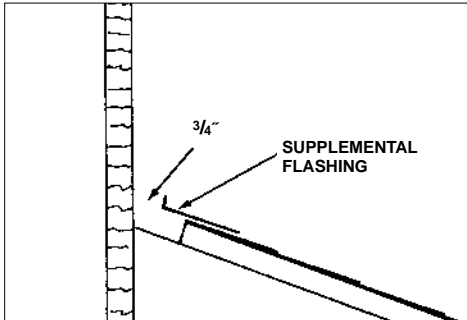

- 7** Place all sections of Flash FilterVent and supplemental flashing over the open slot, extending the vent and flashing the full length of the roof.

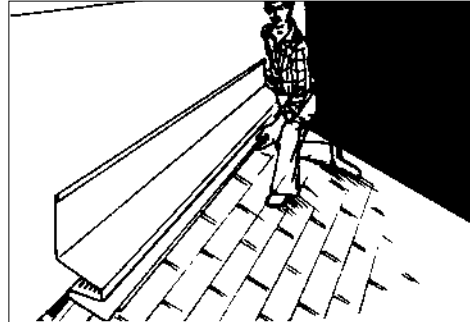

- 8** Insert end plugs.



- 9** Butt Flash FilterVent sections with connector plugs, centering so that half of each plug is in each section. (Connector straps should be installed in Step 11 below).



- 10** Cut final section of Flash FilterVent to the correct length. Extend Flash FilterVent past ends of slot to full length of roof.

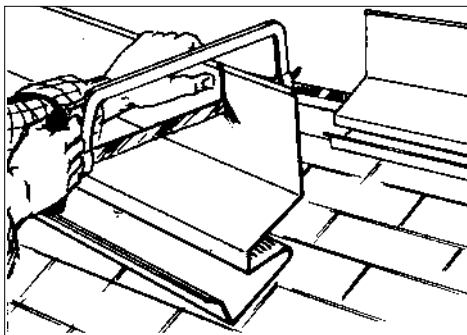

- 11** Align joined Flash FilterVent over slot to chalk line and nail in place on both roof and sidewall, using pre-punched holes and nails as supplied. Fasten straps over joints and nail in place.



### IMPORTANT TIPS

When planning to install Flash FilterVent on a new building with a cathedral ceiling, it is necessary to maintain sufficient clearance between the top of the insulation and the bottom of the roof sheathing to allow air passage from the soffit or eave vent to the Flash FilterVent.

## INSTALLATION – EXISTING ROOFS

- 1** Measure 1¼" to 3" down from the flashing on existing wall and snap a chalk line the entire length of the roof.



- 2** Measure back from inside of house walls 6" at each end and draw line from existing flashing to chalk line. This outlines portion of roof to be removed.

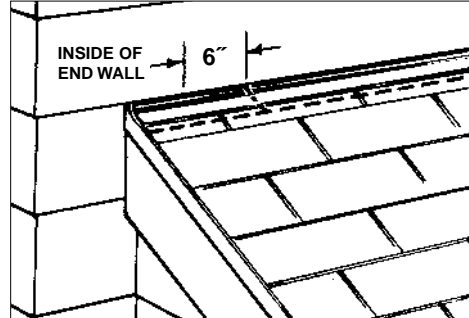

- 3** Cut through shingles along chalk and end lines, using a utility knife, and strip out shingles and tar paper in the slot area, down to the roof sheathing.

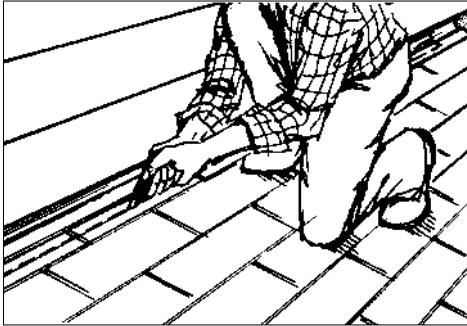

- 4** If existing flashing extends past opening, cut through flashing and sheathing, using metal-cutting saw blade. Use a power saw to cut through roof sheathing, set at depth ¼" greater than sheathing. Cut out slot as marked. Remove cut out portions of sheathing and flashing.



- 5** Loosen or remove lowest piece of siding on vertical wall so that vertical flange of Flash FilterVent and supplemental flashing can slip under it. It may be necessary to cut the lowest course of siding narrower in order to fit the supplemental flashing and Flash FilterVent in place.

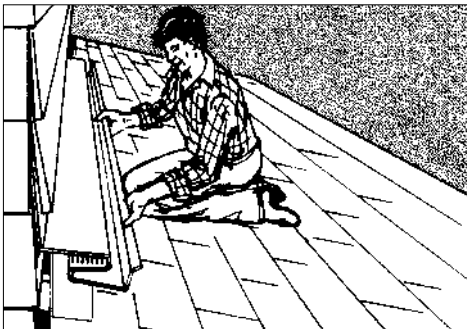

## CHIMNEYS

Cut slots to within 12" of chimney. Run Flash FilterVent from end of roof to butt against chimney.

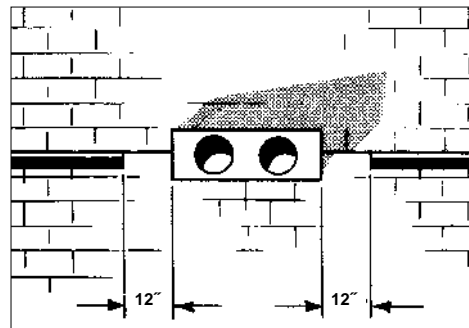

**NEXT, Follow steps 3 through 11 for New Construction Installation**